

CODIGO	F. INS. [Kg] MACHO MAX.	F. 1° EXT. [Kg] MACHO MAX.	EXT. [Kg] MACHO MIN. LUEGO DE 30 MANIOBRAS CON MACHO MAXIMO	SEC. CONDUCTOR [MM. ²]	OBS.
11053xx501 (53.501)	≤ 2.0	≤ 1.7	≥ 0.15	0.50 / 1.50	

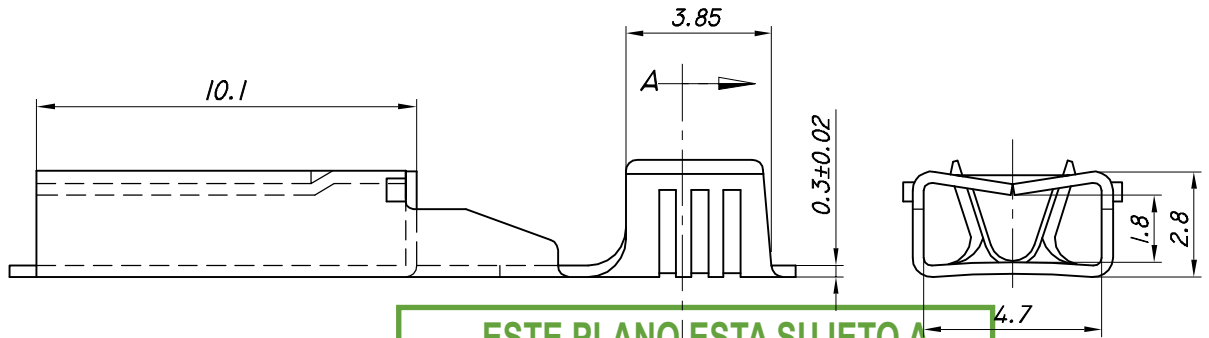

ESTE PLANO ESTA SUJETO A MODIFICACIONES SIN PREVIO AVISO

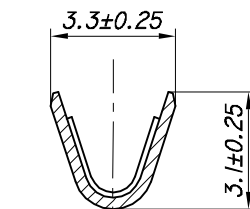
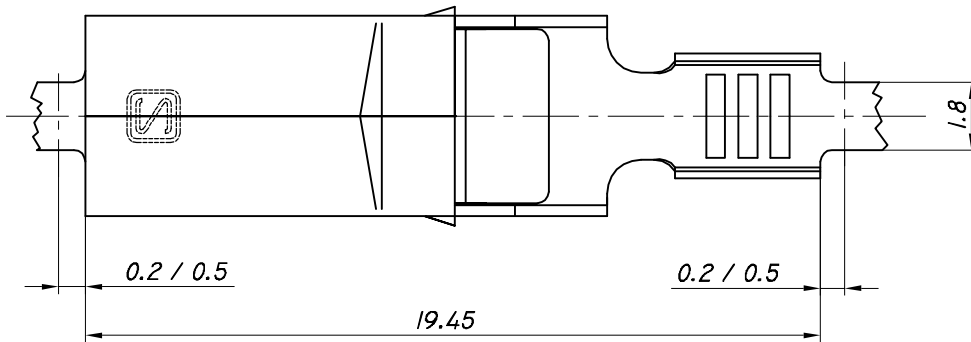

COPIA NO CONTROLADA

CORTE A-A

FECHA	N°	MODIFICACIONES	DIBUJO	REVISO	APROB
 INDUSTRIAS ZETA S.R.L.		TOLERANCIA NO ACOTADA: LINEAL: ±0.15 ANGULAR: ± 1° 30'			
MATERIAL: LATON		ESCALA: 4 :1	DIBUJO	REVISO	APROBO
CODIGO MAS: /E = TERMINACION ESTAÑADA /N = TERMINACION NIQUELADA /P = TERMINACION PLATEADA /S = PIEZA SUELTA		HOJA: 3 DE 3	P.S. 12.08.14		
DEFINOMINACION: TERMINAL HEMBRA COMPUTACION C/ TAPA			PLANO PARA	5.3000	